



USE & CARE GUIDE

B100 SINGLE-CUP BREWING SYSTEM

BREWING EXCELLENCE ONE CUP AT A TIME



ANSI/NFPA 4

For Household and Commercial Use.



Part # 71-000039-003

Revision E, May, 2004

WARRANTY

Limited One Year Warranty

Keurig warrants that your Keurig B100 Brewer will be free of defects in materials or workmanship under normal home use for one year from the date of purchase. Keurig will, at its option, repair or replace the Brewer without charge upon its receipt of proof of the date of purchase. If a replacement Brewer is necessary to service this warranty, the replacement Brewer may be new or reconditioned. If a replacement Brewer is sent, it will carry the remaining warranty of the original product. Keurig will cover all shipping costs for authorized returns.

This warranty only applies to Brewers operated in the United States and Canada. This warranty gives you specific legal rights, and you may also have other rights that vary from state to state and, in the case of Canada, from Province to Province.

What is not covered by the Limited Warranty?

THIS WARRANTY DOES NOT COVER CONSEQUENTIAL OR INCIDENTAL DAMAGES SUCH AS PROPERTY DAMAGE AND DOES NOT COVER INCIDENTAL COSTS AND EXPENSES RESULTING FROM ANY BREACH OF THIS WARRANTY, EVEN IF FORESEEABLE. Some states or Provinces do not allow the exclusion or limitations of incidental or consequential damages, so the above limitation or exclusion may not apply to you depending on the state or Province of purchase.

Nor does this warranty cover damages caused by services performed by anyone other than Keurig or its authorized service providers, use of parts other than genuine Keurig parts, or external causes such as abuse, misuse, inappropriate power supply or acts of God.

Other Limitations

THIS WARRANTY IS EXCLUSIVE AND IS IN LIEU OF ANY OTHER EXPRESS WARRANTY, WHETHER WRITTEN OR ORAL. THE DURATION OF ANY IMPLIED WARRANTIES, INCLUDING BUT NOT LIMITED TO ANY IMPLIED WARRANTIES OF MERCHANTABILITY OR FITNESS FOR A PARTICULAR PURPOSE, IS EXPRESSLY LIMITED TO THE PERIOD OF DURATION OF THIS LIMITED WARRANTY. Some states or Provinces do not allow limitations on how long an implied warranty lasts, so the above limitation may not apply to you depending on the state or the Province of purchase.

How do you obtain warranty service?

Keurig Brewers are high quality appliances and, with proper care, are intended to provide years of satisfying performance. However, should the need arise for warranty servicing, simply call Keurig Customer Service at our toll free phone number 1-866-901-BREW (2739). Please do not return your Brewer for servicing without first speaking to Keurig Customer Service to obtain an Authorization to Return number (ATR). Keurig Brewers returned without an ATR number will be returned to the sender without servicing.

Keurig, Inc.
101 Edgewater Drive
Wakefield, MA 01880

KEURIG B100

Single-Cup Brewing System Use & Care Guide

TABLE OF CONTENTS

SECTION 1	SAFE OPERATION & USE	
	Important Safeguards	1
SECTION 2	SET-UP & OPERATION	
	Helpful Hints	2
	Unpacking	3
	Features of the B100 Brewer	4
	Assembly	5
	Set-Up & First Brew	5
SECTION 3	CONTROLS & INDICATORS	
	Brewer Control Panel	7
	Water Level Indicator	8
SECTION 4	CARE & MAINTENANCE	
	Cleaning Exterior Parts	9
	Cleaning the K-Cup Holder Assembly	9
	Draining & Storing Your Keurig Brewer	10
	De-Scaling Your Keurig Brewer	10
	Eliminating Potential Plastic Odor	12
SECTION 5	TROUBLESHOOTING	13

SECTION 1

SAFE OPERATION & USE

Important Safeguards

When using electrical appliances, basic safety precautions should always be followed, including the following:

1. Read all Instructions.
2. Do not touch hot surfaces.
3. To protect against fire, electric shock and injury to persons do not immerse cord, plugs, or the appliance in water or other liquid.
4. Close supervision is necessary when any appliance is used by or near children.
5. Unplug from outlet when not in use and before cleaning. Allow to cool before putting on or taking off parts, and before cleaning the appliance.
6. Do not operate any appliance with a damaged cord or plug or after the appliance malfunctions, or has been damaged in any manner. Return appliance to the nearest authorized service facility for examination, repair or adjustment.
7. The use of accessory attachments not recommended by the appliance manufacturer may result in fire, electric shock or injury to persons.
8. Do not use outdoors.
9. Do not let cord hang over edge of table or counter, or touch hot surfaces.
10. Do not place on or near a hot gas or electric burner, or in a heated oven.
11. Plug cord into the wall outlet and turn switch to "on". To disconnect, turn any control to "off", then remove plug from wall outlet.
12. Do not use appliance for other than intended use.
13. Do not overfill with water.
14. For best operation, plug the appliance into its own electrical outlet on a dedicated circuit to prevent flickering of lights, blowing of fuses or tripping a circuit breaker.
15. This appliance is equipped with a power cord having a grounding wire with a grounding plug. The appliance must be grounded by using a 3-hole properly grounded outlet. In the event of an electrical short circuit, grounding reduces the risk of electrical shock.
16. If the outlet is a standard 2-prong wall outlet, it is your personal responsibility and obligation to have it replaced with a properly grounded 3-prong wall outlet.
17. Do not, under any circumstances, cut or remove the third (ground) prong from the power cord or use an adapter.
18. Consult a qualified electrician if the grounding instructions are not completely understood, or if doubt exists as to whether the appliance is properly grounded.
19. This appliance must be properly installed and located in accordance with these instructions before it is used.

SAVE THESE INSTRUCTIONS.

SECTION 2

SET-UP & OPERATION

Helpful Hints

1. Keep your Keurig Brewer turned “ON” all the time.

For a fresh cup of coffee or tea anytime you want, we suggest you keep your Keurig Brewer turned “ON” all the time. The Brewer draws minimal power (approximately the equivalent of a 60 Watt light bulb).

2. Turn Brewer “OFF” if you do not plan to use it for a week or longer.

Turn Brewer to “OFF” and unplug it if you do not plan to use it for a week or more. Drain the water if you wish. Please follow the draining instructions in the Care & Maintenance section on page 10 of this guide.

TURNING YOUR BREWER BACK ON.

When you turn it back on, a full tank of water will take approximately 8 – 10 minutes to heat fully from room temperature. To brew your first cup sooner, do not completely fill the tank. Less water in the tank will allow the water to heat up faster.

3. Plug the Brewer into its own outlet.

Plug the Brewer into its own outlet. If the electric circuit is overloaded with other appliances, your Brewer may not function properly. The Brewer should be operated on its own circuit, separate from other appliances.

4. Water varies from place to place.

Mineral and chlorine content in water varies from place to place. If you notice an undesirable taste in your cup of coffee such as chlorine or other mineral taste, you should consider using bottled water or water from a filtration system such as Brita®.

To remove chlorine taste or odor, you may also purchase a Charcoal Filter designed for your Brewer on our website at www.keurig.com.

5. The Brew Button will only work when the Green “Ready” Light is flashing. After closing the Brew Drawer, it will flash for 60 seconds, during which time you can press the Brew Button. If you do not push the Brew Button in 60 seconds, the Brew Button will be disabled to prevent accidental activation. Re-activate the Brew Button by opening and closing the Brew Drawer.

6. Filling the Brewer

The Water Fill Lid is designed to close automatically to prevent hot water or steam from escaping through a lid that may have been left accidentally open. If filling the Brewer is a bit difficult because it is positioned under a cabinet, simply grasp the Brewer by the lower part of the front, side panels and pull toward you. The base is specially constructed to make sliding the Brewer easy.

Unpacking

Carefully remove the Brewer from its package and check the contents of this box.

It should contain the following:

Parts Checklist:

- 1. K-Cup Holder Assembly (preassembled)
 - 1 K-Cup Holder
 - 1 Funnel
 - 2. Keurig B100 Brewer
 - 3. Drip Tray Assembly consisting of
 - 1 Drip Tray
 - 1 Drip Tray Plate
 - 1 Cleaning Tool (under Drip Tray)
-

- 1. K-Cup Holder Assembly (preassembled)
 - 1 K-Cup Holder
 - 1 Funnel

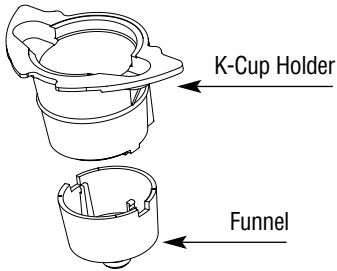

- 2. Keurig B100 Brewer

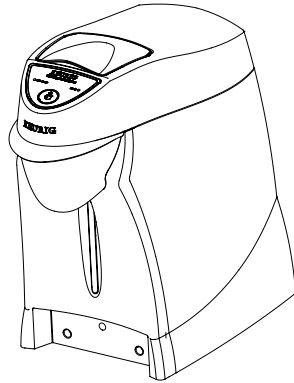

- 3. Drip Tray Assembly
 - 1 Drip Tray
 - 1 Drip Tray Plate

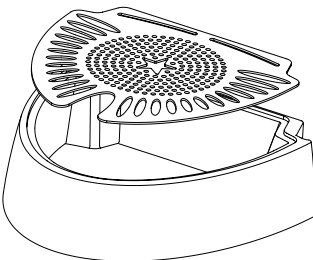

- 1 Cleaning Tool

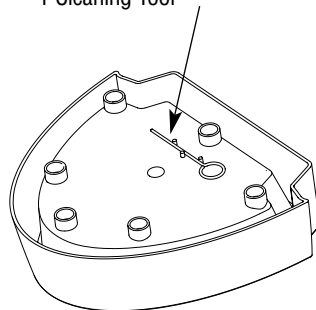

Features of the B100 Brewer

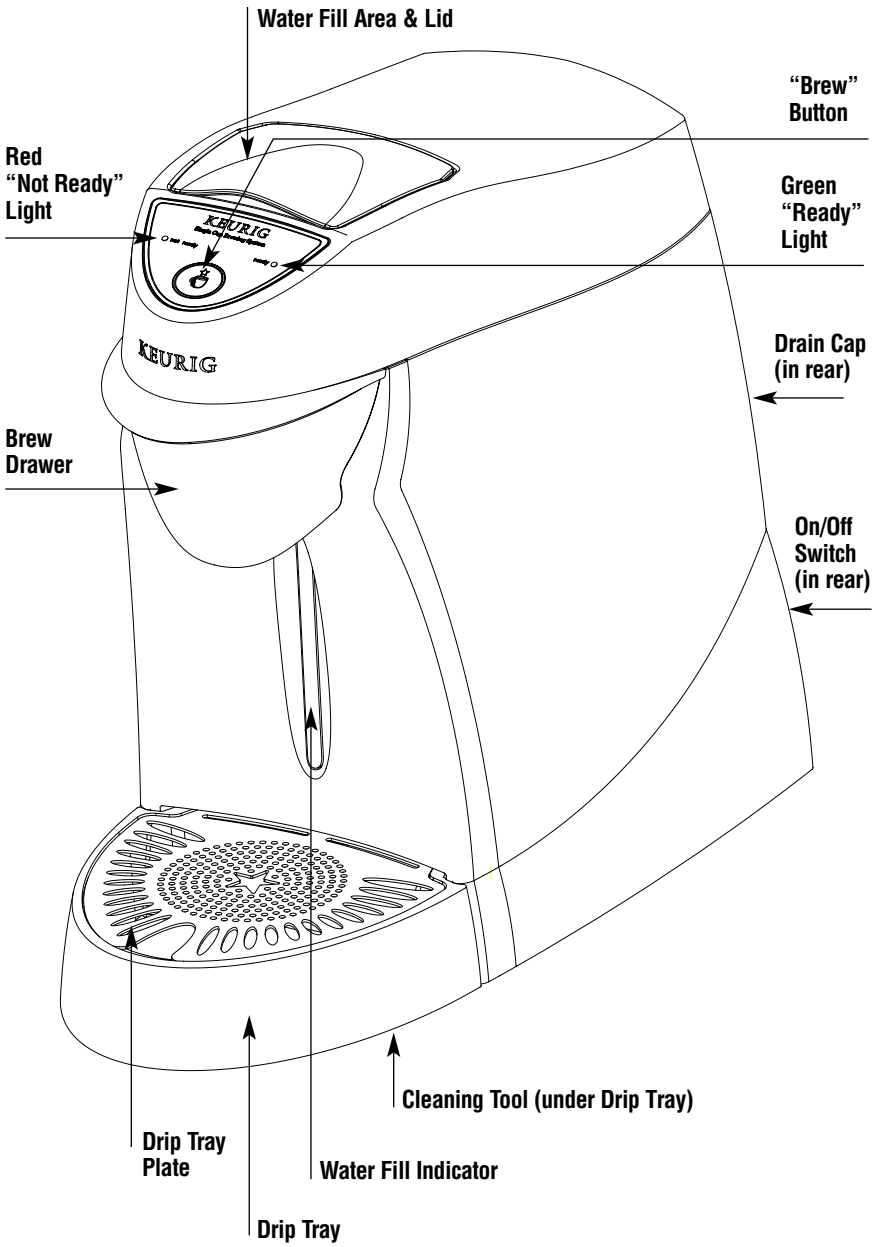

Assembly

1. Drip Tray Assembly

- a. Ensure that Drip Tray Plate rests on Drip Tray.
- b. Place Drip Tray Assembly at the front base of the Brewer.

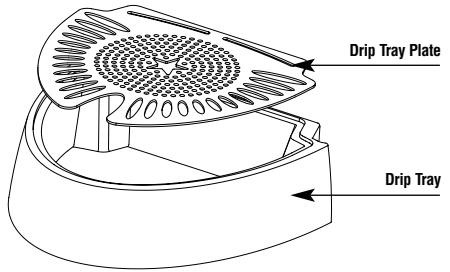

2. K-Cup Holder Assembly

- a. Open the Brew Drawer.
- b. Insert K-Cup Holder Assembly into the Brew Drawer and press down until the K-Cup Holder Assembly snaps firmly in place.

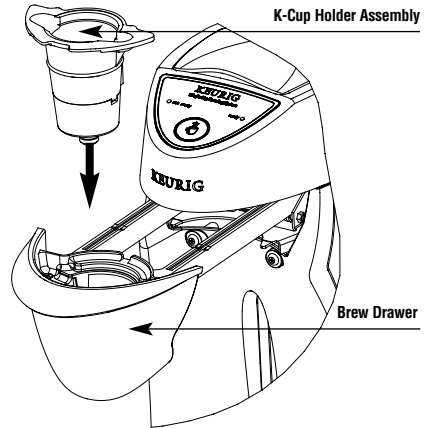

NOTE: The K-Cup Holder and Funnel can become separated during shipping. To reassemble, line up the notch in the Funnel (lower section) with the tabs in the K-Cup Holder (top section). Position one post from the Funnel into the square hole on the underside of the K-Cup Holder. Snap the other post into place.

Set-Up & First Brew

1. Power

- a. Plug Brewer in.
- b. Turn power switch found on rear of Brewer to "ON" setting.
- c. The Red "Not Ready" Light on the Brewer Control Panel will come on and the blue light behind the Water Level Indicator will flash on and off. This indicates the Brewer needs water.

2. Fill with Water

- Lift the Water Fill Lid and hold it open.
- Fill the Brewer with up to 80 oz of water on the initial fill (regular re-fill quantity is 64 oz) by pouring water into the Water Fill Area.
- The Water Fill Indicator will be flashing with a blue light while you are filling or re-filling, and will stop flashing when water passes the minimum fill level.
- The Brewer will indicate that it has reached the full water level with four flashes of the Green "Ready" Light and 4 audible beeps.

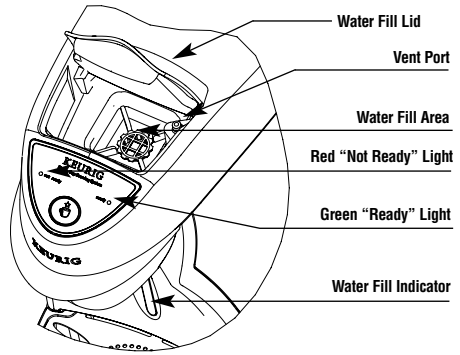

The Red "Not Ready" Light indicates the Brewer is not ready (the water is heating). Wait for 8 – 10 minutes. The Green "Ready" Light will illuminate when the water has reached the proper temperature for brewing.

3. Perform Eight Cleansing Brews First

- Place a mug on the Drip Tray Plate.
- Open and close the Brew Drawer, green light will flash.
- Press the Brew Button and hot water will dispense into the mug.
- Pour hot water into the sink.
- Repeat until brewer is empty.

CAUTION: When refilling the Brewer, it is possible for hot steam to escape. Take care not to position your hand directly over the Vent Port located on the right side of the Water Fill Area.

4. Brew and Enjoy a Fresh Brewed Mug

- Refill the brewer with water and allow to heat.
- Place a mug on the Drip Tray.
- Open the Brew Drawer and insert a K-Cup into the K-Cup Holder as shown.
- Close the Brew Drawer (flashing Green "Ready" Light signals ready to brew).
- Press the Brew Button to start the brewing process.
- After an air purge completes the 45 second brew process, open the Brew Drawer and remove and dispose of the used K-Cup.
- Enjoy your fresh brewed coffee or tea!
- Your Brewer is ready to brew your next mug.

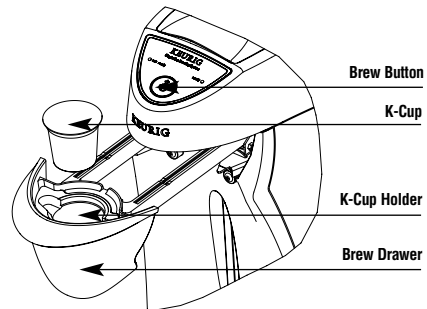

NOTE: Do not remove the foil lid or puncture the K-Cup.



NOTE: Remember, the Brew Button will not work if the Green "Ready" Light is not flashing. Open and close the Brew Drawer to reactivate the Brew Button.

SECTION 3

CONTROLS & INDICATORS

Brewer Control Panel

Controls operation and indicates the brewing system status.

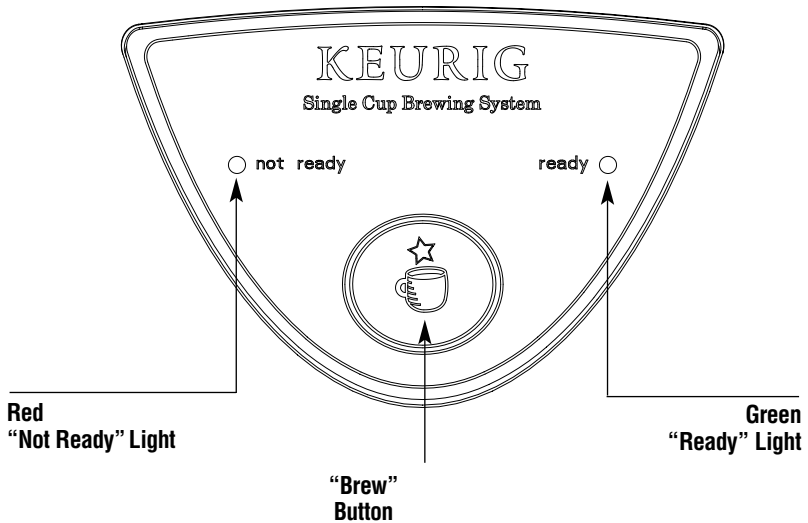

Control Panel Indicators	Display	Meaning
Red "Not Ready"	Solid	Not Ready - needs water or is heating water.
	Flashing	May need to be de-scaled or serviced. Refer to Troubleshooting on page 13.
Green "Ready"	Solid	Water has reached correct temperature OR coffee is brewing.
	Flashing	Brew Drawer has been opened and closed activating the Brew Button for 60 seconds. NOTE: Remember, the Brew Button will not work if the Green "Ready" Light is not flashing. Open and close the Brew Drawer to reactivate the Brew Button.
	4 Flashes & 4 Beeps	Stop filling with water. Water level has reached full.

Water Level Indicator

Indicates the amount of water and water system status.

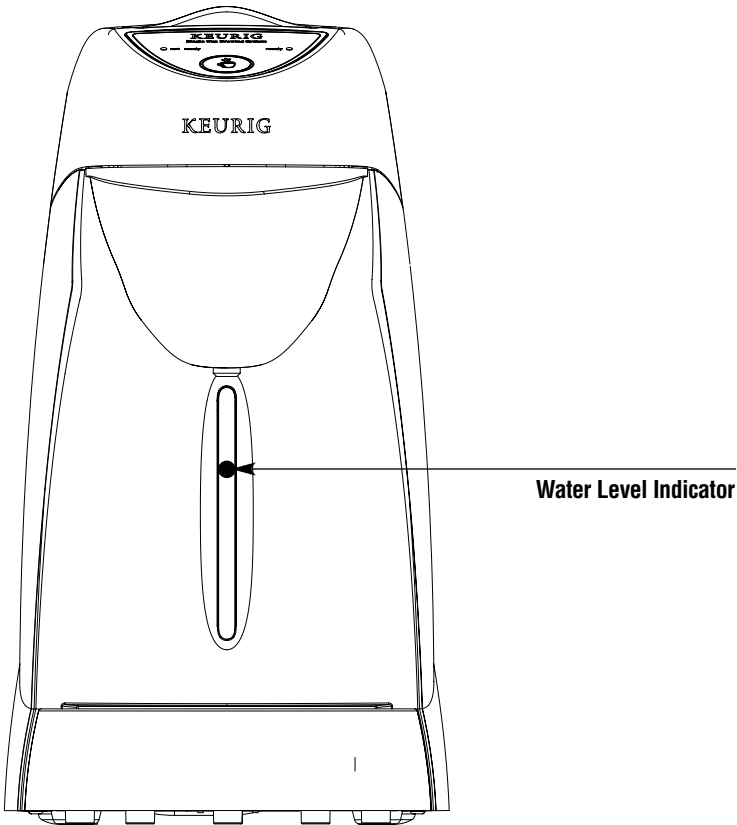

Water Level Indicators	Display	Meaning
Water Fill Indicator	Solid Blue	Has sufficient water.
	Flashing Blue	Needs water.
	Flashing Yellow	De-scale Brewer (See instructions on page 10). If you have de-scaled the Brewer and the light is still flashing yellow, the Brewer may need service – contact customer service at 1-866-901-BREW (2739).
	Flashing Red	Needs service – contact customer service at 1-866-901-BREW (2739).

SECTION 4

CARE & MAINTENANCE

Cleaning Exterior Parts

Regular cleaning of the Brewer's external components is recommended.

- a. Housing: the Housing and other exterior components may be cleaned with a soapy, damp non-abrasive cloth.
- b. Drip Tray & Drip Tray Plate: the Drip Tray can accumulate up to 16 oz of overflow. The Drip Tray and Drip Tray Plate should be periodically inspected and rinsed clean. To remove the Drip Tray Assembly, simply slide it toward you, keeping it level at all times, to avoid spilling. The Drip Tray and Drip Tray Plate are dishwasher safe.

Cleaning the K-Cup Holder Assembly

a. Cleaning the Parts

The K-Cup Holder Assembly consists of the K-Cup Holder and Funnel, and can be removed for cleaning. Both parts are dishwasher safe. To remove from the Brewer, grasp the Brew Drawer with your thumbs and the bottom of the Funnel with your fingers. Push the Funnel straight up while holding the Brew Drawer firmly. (Refer to the Assembly instructions on page 5 to put the K-Cup Holder Assembly back together after cleaning).

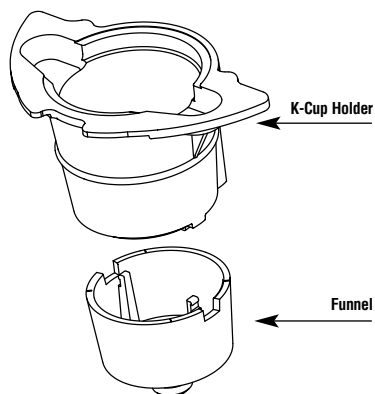

b. Cleaning the Exit Needle

The Exit Needle is located on the inside bottom of the K-Cup Holder Assembly. Should a clog arise due to coffee grinds, it can be cleaned using the Exit Needle Cleaning Tool which can be found on the underside of the Drip Tray. Insert the Cleaning Tool into the Needle to loosen the clog and push it out. Wash with warm, soapy water and rinse thoroughly. **CAUTION: The Exit Needle is sharp.**

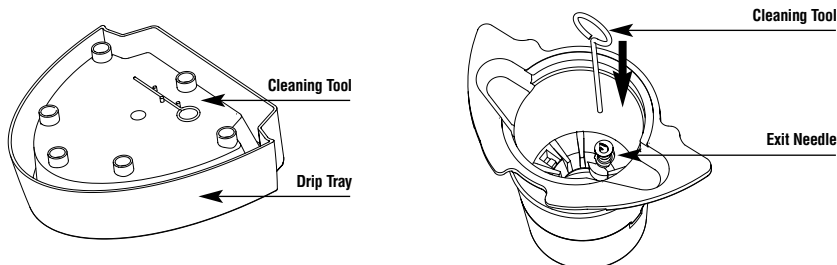

c. Water Fill Area and Lid

Use a clean cloth soaked in hot water to wipe the Water Fill Area and Lid clean.

CAUTION: Please ensure that no cleaners or cleaning solutions are used in or near the fill area as they may contaminate the water supply in the Brewer.

Draining & Storing Your Keurig Brewer

You can drain the water from your Keurig Brewer if you are going to move it, store it or not use it for more than a week.

To drain your Keurig Brewer, please follow these instructions:

- a. Turn power "OFF" and unplug the Brewer.
CAUTION: Water is hot, please allow it to cool before draining.
- b. Carry Brewer to the sink making sure that it stays upright.
- c. Remove the Drain Cap on rear of Brewer and, if present, remove Charcoal Filter from the Water Fill Area.
- d. Rest the rear of the Brewer flat on the counter with the drain positioned over the sink and allow Brewer to drain. For best results, do not tilt beyond a 90° angle.
- e. Once water is drained, **replace the Drain Cap** and, if used, the Charcoal Filter. Your Brewer is now ready to be moved, stored or refilled.

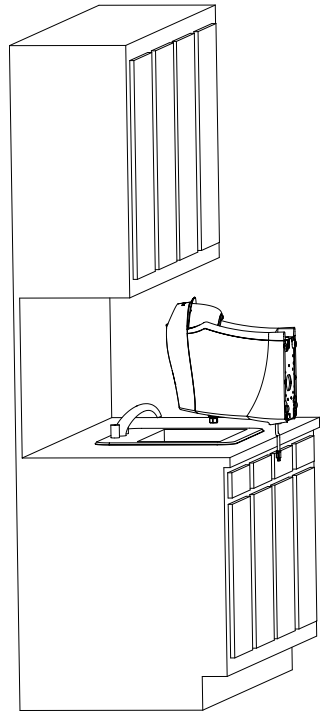

De-scaling Your Keurig Brewer

Mineral content in water varies from place to place. Depending on the mineral content of the water in your area, scale may build up on your Brewer. Scale is non-toxic, but left unattended, it can hinder optimal Brewer performance. De-scaling your Brewer regularly helps maintain the heating element, water tank and other parts of the Brewer that come in contact with water. Better water quality and water heating means a better cup of coffee. We recommend de-scaling your Brewer at least every 6 months (every three months if your water has high mineral content).

You will need to de-scale your Brewer if you get a flashing yellow light behind the water fill tube. The Brewer will not work properly if the yellow light is flashing.

It will take approximately 4½-5 hours to de-scale your Brewer. Properly follow the de-scaling procedure on the following page.

a. PREPARE

Step 1: Make sure you have at least 64 oz. of undiluted white vinegar on hand.

You will also need an empty sink and a ceramic mug (do not use a paper cup).

Step 2: Turn power “OFF”, remove Charcoal Filter (if any) and drain the Brewer as instructed in the Care & Maintenance section on page 10 of this guide.

CAUTION: Water may be hot. Remember to replace the Drain Cap.

b. FILL AND CLEAN

Step 1: Plug Brewer in and turn power “ON”.

Step 2: Pour approximately 64 oz of the vinegar into the Brewer until 4 beeps signal the tank is full.

Step 3: Wait about 6 – 8 minutes for the vinegar to heat up and the Green “Ready” Light to go on.

Step 4: Place a ceramic mug on the Drip Tray and run a brew cycle. Do not use a K-Cup, just press the brew button.

Step 5: Repeat the brew process 4 times, pouring the contents of the mug **back into the brewer** after each cycle.

Step 6: Now let the Brewer stand for 4 hours while still on.

Step 7: Place the ceramic mug on the Drip Tray and run 4 brew cycles, pouring the contents of the mug **into the sink** after each cycle.

Step 8: Drain the Brewer as instructed in the Care & Maintenance section on page 10 of this guide. **CAUTION: Vinegar may be hot. Remember to replace the Drain Cap.**

c. RINSE

Step 1: Power up Brewer when empty.

Step 2: Fill the Brewer with hot tap water.

Step 3: Wait about 6 – 8 minutes for the water to heat up and the Green “Ready” Light to go on.

Step 4: Place a ceramic mug on the Drip Tray and run a brew cycle.

Step 5: Repeat brew process 4 times for a total of 5 cycles.

Step 6: Drain the Brewer as instructed in the Care & Maintenance section on page 10 of this guide.

CAUTION: Water may be hot. Remember to replace the Drain Cap.

Step 7: You may need to rinse again to eliminate any residual taste.

Eliminating Potential Plastic Odor

Like many new products, you may notice a slight plastic or metallic odor. If this persists, we recommend this cleaning procedure to eliminate any odor.

a. PREPARE

Step 1: Turn power “OFF”, unplug and drain the Brewer as instructed in the Care and Maintenance section on page 10 of this guide.

CAUTION: Water may be hot. Remember to replace the Drain Cap.

Step 2: Add 1 tablespoon of baking soda **OR** 2 tablespoons of white vinegar to 2 cups (16 oz) of warm water; stir the water to fully dissolve the baking soda or white vinegar. Pour this solution into the Brewer.

Step 3: Plug Brewer in, turn power “ON” and add 6 more cups of fresh water, or until the Brewer is full. (Indicated by four flashes of the green light and 4 beeps.) Wait for water to reach brewing temperature (Green “Ready” Light will go on.) This should take 6 - 8 minutes.

b. FILL AND CLEAN

Step 1: When ready, place a mug or cup on the Drip Tray, open and close the Brew Drawer, and press the Brew Button to run a brew cycle. **DO NOT INSERT A K-CUP.** Pour contents of the mug back into the Brewer. Repeat this step for a total of 4 cycles

Step 2: When step 1 is complete, let the Brewer sit for 30 minutes.

Step 3: Turn power “OFF” and drain the Brewer as instructed in the Care and Maintenance section on page 10 of this guide.

CAUTION: Water may be hot. Remember to replace the Drain Cap.

c. RINSE

Step 1: Fill the Brewer with fresh water. Turn Brewer “ON” and wait 6 – 8 minutes for the water to heat up and the Green “Ready” Light to go on.

Step 2: When ready, place a mug or cup on the Drip Tray; open and close the Brew Drawer, and press the Brew Button to run a brew cycle. **DO NOT INSERT A K-CUP.** Repeat this step until flashing blue light indicates that the Brewer needs water (about 8 cycles).

Step 3: Turn power “OFF” and drain the Brewer as instructed in the Care and Maintenance section on page 10 of this guide.

CAUTION: Water may be hot. Remember to replace the Drain Cap.

d. READY TO BREW COFFEE OR TEA

Now you are ready to brew coffee or tea again. Plug Brewer in, turn power “ON”, fill with fresh water, wait for the water to reach brewing temperature (Green “Ready” Light will go on), insert K-Cup, and brew.

SECTION 5

TROUBLESHOOTING

SITUATION

SOLUTION

Brewer Does Not Have Power

Check to be sure it is plugged in securely.
Plug into a different outlet.
Reset circuit breaker if necessary.

**Brewing a Partial Cup
(Less than 6 oz.)**

Ensure Exit Needle is not clogged.
Clean K-Cup Holder Assembly if necessary
and rinse under faucet (See page 9).
If problem persists, call Customer Service
at 1-866-901-BREW (2739).

Water Fill Indicator is Flashing Blue

Brewer is empty, add water.

**Green “Ready” Light is on,
but you can’t Brew**

Open and close Brew Drawer. Green light
will flash. Push the Brew Button.
The Brew Button is disabled if the
user does not brew within 60 seconds of
closing the Brew Drawer. This prevents
accidental activation.

**Red “Not Ready” Light Flashing and
Yellow Light on Water Indicator is Flashing**

De-scale Brewer following procedure
on page 10.
If lights persist, water level sensor is
blocked call Customer Service at
1-866-901-BREW (2739) and turn off.

**Red “Not Ready” Light Flashing and
Red Light on Water Indicator Solid
or Flashing**

Turn off Brewer and call Customer
Service at 1-866-901-BREW (2739).

**Slight Plastic or Metallic Smell in
Coffee, Tea or Hot Water**

Follow procedure to eliminate this smell
on page 12 of this guide

TO CONTACT CUSTOMER SERVICE:

www.keurig.com

or

1-866-901-BREW (2739)

Made in USA

Keurig, Keurig-Brewed, Brewing Excellence One Cup at a Time,
and K-Cup are registered trademarks of Keurig, Inc.

©2003 Keurig, Inc.

All rights reserved.